

Motorized Pulley 500L & 500M, Ø 500 mm

Motorized Pulley
with terminal box

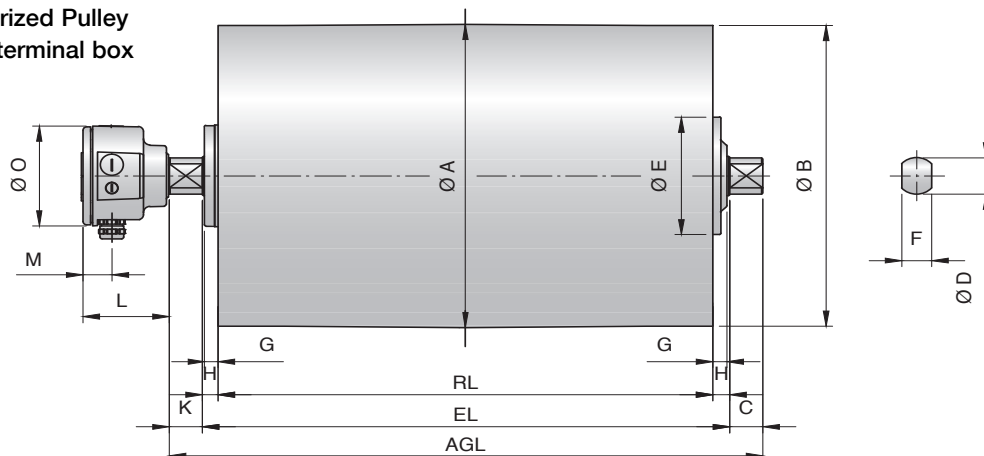

Idler Pulley
UT400M & UT400H

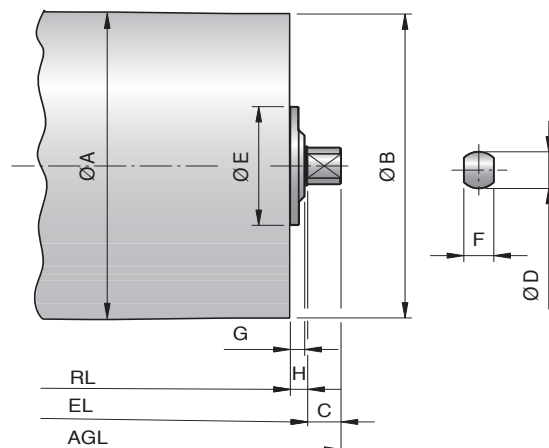

Type	Motorized Pulley or Idler Pulley (UT)										Larger terminal box			
	A mm	B mm	C mm	D mm	E mm	F mm	G mm	H mm	K mm	L mm	M mm	N mm	O mm	
500L & 500M	501	497	50	60	194	45	23	25	50	131	46	-	165	
UT400M & UT400H	404	400	50	60	168	45	20	25	-					

Mounting bracket KL60

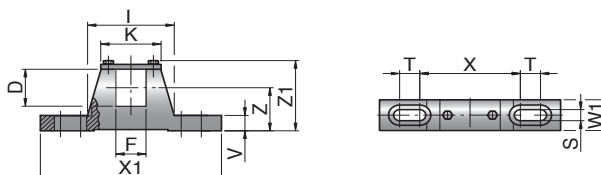

Motorized Pulleys & Idler Pulleys (UT) Type	Material	Bracket description	Dimensions												Weight kg
			D mm	F mm	I mm	K mm	S mm	T mm	V mm	W1 mm	X mm	X1 mm	Z mm	Z1 mm	
500L & 500M and UT400M & UT400H	Steel	KL60	60	45	130	90	18	30	25	50	150	270	70	115	4.8